

1.2V to 3.6V Universal Bi-directional Level Shifter with Automatic Direction Control

Features

- Designed for low voltage operation: 1.2V to 3.6V
- Universal bidirectional level shifting without direction control
- Fast bus speeds up to 180 Mbps
- Drive Capability 12mA
- Independent transition of each bit
- Each supply rail is configurable over supply range
- ESD Protection exceeds JESD22
 - 2000V Human Body Model (A114-B)
 - 200V Machine Model (A115-A)
- Latch-up performance exceeds 100mA per JESD 78
- Industrial operation at -40°C to $+85^{\circ}\text{C}$
- Packaging (Pb-free & Green):
 - 56-contact plastic 197-mil TQFN (ZF56)

Description

Pericom Semiconductor's PI4ULS3V16 is a 16-bit (dual-octal) non-inverting bus transceiver with two separate supply rails. A port (V_{CCA}) and B port (V_{CCB}) are set to operate at 1.2V to 3.6V. This arrangement permits universal bidirectional translation of differential signal levels over the voltage ranges.

PI4ULS3V16 is designed for asynchronous communication between data buses. Data is transmitted from the A bus to the B bus, or vice versa, without direction control. All A_X and B_X are tri-stated when data is coming from both directions at the same time. The output-enable (\overline{OE}) input is used to disable outputs so buses are isolated.

The control pins, ${}_x\text{SEL}$, ${}_x\overline{OE}$, TEST_EN and OUT_SEL are supplied by V_{CCB} .

To ensure the high-impedance state during power-up or power-down, the output-enable (\overline{OE}) input should be tied to V_{CC} through a pullup resistor.

Applications

- Voltage Translation
- Bus Relay

Block Diagram

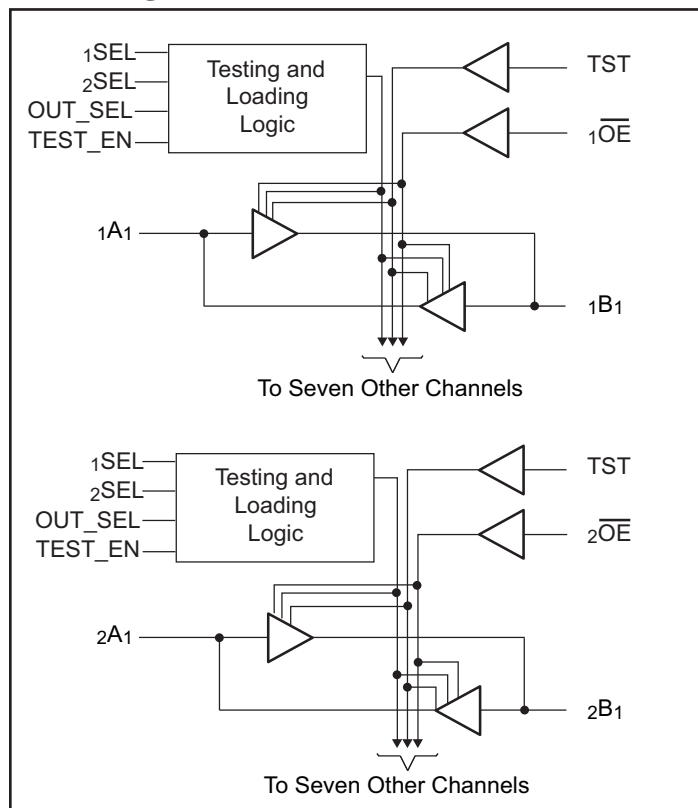

Maximum Ratings

(Absolute maximum ratings over operating free-air temperature range, unless otherwise noted)

<p>Supply voltage range: V_{CCA}..... -0.5V to 4.6V</p> <p style="padding-left: 100px;">V_{CCB}..... -0.5V to 4.6V</p> <p>Input voltage range, $V_I^{(1)}$ Control Inputs..... -0.5V to 4.6V</p> <p>Voltage Range applied to any I/O pins in the high-impedance or Power-Off state, $V_{IO}^{(1)}$:</p> <p style="padding-left: 100px;">A Port -0.5V to 4.6V</p> <p style="padding-left: 100px;">B Port..... -0.5V to 4.6V</p> <p>Voltage Range applied to any I/O pins in the High or Low state $V_{IO}^{(1, 2)}$:</p> <p style="padding-left: 100px;">A Port -0.5V to $V_{CCA} + 0.5V$</p> <p style="padding-left: 100px;">B Port..... -0.5V to $V_{CCB} + 0.5V$</p>	<p>Input clamp current, $I_{IK} (V_I < 0)$..... -50mA</p> <p>Output clamp current, $I_{OK} (V_O < 0)$..... -50mA</p> <p>Continuous output current, I_O $\pm 20mA$</p> <p>Continuous current through V_{CCA}, V_{CCB} or GND $\pm 100mA$</p> <p>Package thermal impedance, $\theta_{JA}^{(3)}$:</p> <p style="padding-left: 100px;">A package..... 82°C/W</p> <p style="padding-left: 100px;">ZF package..... 33°C/W</p> <p>Storage temperature range, T_{STG} -65°C to 150°C</p>
--	---

Note:

1. The input negative voltage and output voltage ratings may be exceeded if the input and output current ratings are observed.
2. This value is limited to 3.6V maximum.
3. The package thermal impedance is calculated in accordance with JESD 51.
4. Stresses greater than those listed under MAXIMUM RATINGS may cause permanent damage to the device. This is a stress rating only and functional operation of the device at these or any other conditions above those indicated in the operational sections of this specification is not implied. Exposure to absolute maximum rating conditions for extended periods may affect reliability.

Pin Configuration - TQFN

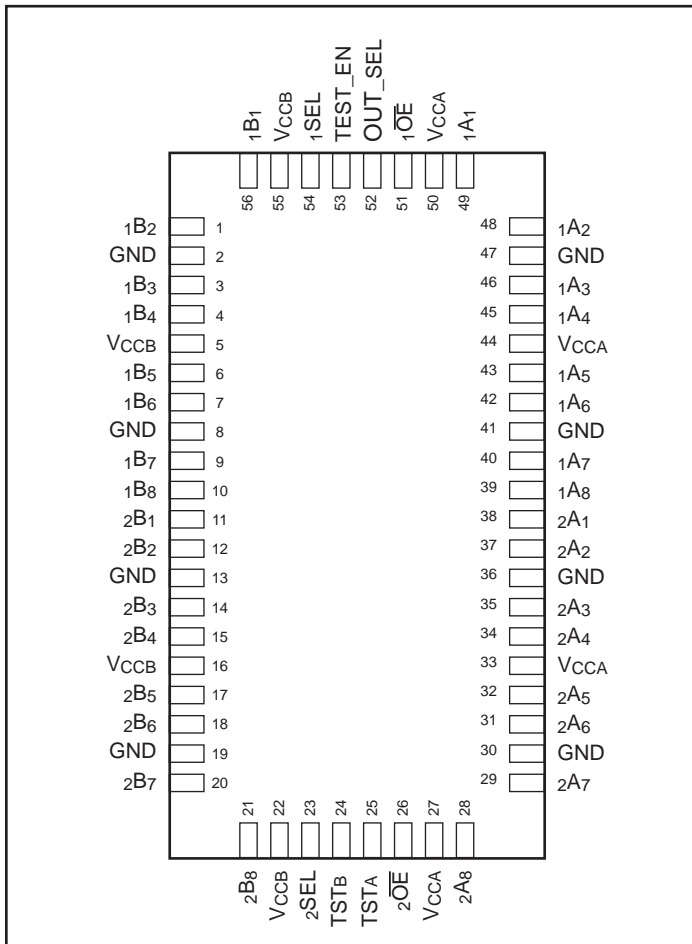

Pin Description

Pin Name	Description
\overline{xOE}	3-State Output Enable Inputs (Active LOW)
$xSEL$	Outputs Loading Selection
xAX	Side A Inputs/Outputs
xBX	Side B Inputs/Outputs
TEST_EN	Enable Test Mode
OUT_SEL	Output impedance Selection
GND	Ground
V_{CCA}, V_{CCB}	Power
TST _X	Internal test pins. For normal usage, please tie to ground.

Truth Table⁽¹⁾

Inputs			Outputs Loading ⁽²⁾	Operation
\overline{xOE}	$_2SEL$	$_1SEL$		
L	L	L	$C_L \leq 50pF$	Bus B data to Bus A, or Bus A data to Bus B
L	L	H	$C_L \leq 30pF$	
L	H	L	$C_L \leq 20pF$	
L	H	H	$C_L \leq 10pF$	
H	X	X		Z (Isolation)

Notes:

- H = HIGH Signal Level
L = LOW Signal Level
X = Don't Care or Irrelevant
Z = High Impedance
- Refer to Figure 1 for Output Loading Chart

Test Mode / Output Impedance Select

TEST_EN	Out_SEL	Condition
L	L	Normal Operation Low output impedance 300Ω
L	H	Normal Operation High output impedance 2.2KΩ
H	L	Test_MODE A → B
H	H	Test_MODE B → A

Recommended Operating Conditions^(1, 2, 3)

Parameter	Description		V _{CCI}	Min.	Max.	Units
V _{CCA} , V _{CCB}	Supply Voltage			1.2	3.6	V
V _{IH}	High-Level Input Voltage	I/O pins	1.2V to 1.95V	0.65 x V _{CCI}		
			2.3V to 2.7V	1.7		
			2.7V to 3.6V	2		
V _{IL}	Low-Level Input Voltage	I/O pins	1.2V to 1.95V		0.35 x V _{CCI}	
			2.3V to 2.7V		0.7	
			2.7V to 3.6V		0.8	
V _{IHB}	High-Level Input Voltage	Control Inputs (OE and SEL)	1.2V to 1.95V	0.65 x V _{CCB}		
			2.3V to 2.7V	1.7		
			2.7V to 3.6V	2		
V _{ILB}	Low-Level Input Voltage	Control Inputs (OE and SEL)	1.2V to 1.95V		0.35 x V _{CCB}	
			2.3V to 2.7V		0.7	
			2.7V to 3.6V		0.8	
V _I	Input Voltage	I/O pins and Control Inputs		0	3.6	
V _O	Output Voltage	I/O pins and Control Inputs		0	3.6	
I _{OH}	High-Level Output Current	I/O pins	V _{CCO} = 1.2V		-3	
			V _{CC} = 1.4V		-5	
			V _{CCO} = 1.65V		-8	
			V _{CCO} = 2.3V		-9	
			V _{CCO} = 3.0V		-12	
I _{OL}	Low-Level Output Current	I/O pins	V _{CC} = 1.2V		-3	
			V _{CCO} = 1.4V		5	
			V _{CCO} = 1.65V		8	
			V _{CCO} = 2.3V		9	
			V _{CCO} = 3.0V		12	
ΔV/Δt	Input Transition rise or fall rate				10	V/ns
T _A	Operating Free-Air Temperature			-40	85	°C

Notes:

1. V_{CCI} is the V_{CC} associated with the data input port.
2. V_{CO} is the V_{CC} associated with the data output port.
3. To ensure proper device operation, all unused device inputs must be held at V_{CCI} or GND.

Electrical Characteristics for (Over recommended free-air temperature range, unless otherwise noted.)⁽³⁾

Parameter	Description	Test Conditions	V _{CCA} /V _{CCB}	Min.	Typ. ⁽¹⁾	Max.	Units
V _{OH}	High-Level Output Voltage	I _{OH} = -100μA	1.2V to 3.6V	V _{CCO} - 0.1V			V
		I _{OH} = -2mA	1.2V		0.8		
		I _{OH} = -4mA	1.4V		1		
		I _{OH} = -7mA	1.65V		1.2		
		I _{OH} = -9mA	2.3V		1.8		
		I _{OH} = -12mA	3.0V		2.4		
V _{OL}	Low-Level Output Voltage	I _{OL} = 100μA	1.2V to 3.6V			0.2	V
		I _{OL} = 2mA	1.2V		0.1		
		I _{OL} = 4mA	1.4V			0.4	
		I _{OL} = 7mA	1.65V			0.4	
		I _{OL} = 9mA	2.3V			0.4	
		I _{OL} = 12mA	3.0V			0.4	
I _{CC}	Quiescent Supply Current	V _I = V _{CCI} or GND, I _O = 0	1.2V to 3.6V			10	μA
I _I	Control Inputs ($\overline{\text{OE}}$ and SEL)	V _I = V _{CCB} or GND	1.2V to 3.6V			±5	
I _{OZ} ⁽²⁾	3-State Output Current	V _O = V _{CCO} or GND	1.2V to 3.6V			±10	
C _{IN}	Control Input Capacitance	V _I = V _{CCB} or GND			3		pF
C _{IO}	I/O Capacitance	V _O = V _{CCA/B} or GND			5		

Notes:

1. All typical values are at T_A = 25°C.
2. For I/O ports, the parameter I_{OZ} includes the input leakage current.
3. Parameters are specified under test mode conditions.

Timing Characteristics for $V_{CCA} = 1.5V \pm 0.1V$

(Over recommended free-air temperature range, unless otherwise noted.)

Parameter	From (Input)	To (Output)	$V_{CCB} = 1.2V$	$V_{CCB} = 1.5V \pm 0.1V$		$V_{CCB} = 1.8V \pm 0.15V$		$V_{CCB} = 2.5V \pm 0.2V$		$V_{CCB} = 3.3V \pm 0.3V$		Units
			Typ	Min.	Max.	Min.	Max.	Min.	Max.	Min.	Max.	
t_{PD}	A	B	8	1.0	7.0	1.0	6.5	1.0	6.0	1.0	5.0	ns
	B	A	6	1.0	7.0	1.0	6.5	1.0	6.0	1.0	5.5	
$t_{SK(a)}^{(1)}$					0.3		0.3		0.3		0.3	
$t_{SK(b)}^{(1)}$					0.25		0.25		0.25		0.25	
f_{max} 10pF load	B	A	25	30		40		50		60		MHz
	A	B	30	30		35		40		40		

Timing Characteristics for $V_{CCA} = 1.8V \pm 0.15V$

(Over recommended free-air temperature range, unless otherwise noted.)

Parameter	From (Input)	To (Output)	$V_{CCB} = 1.2V$	$V_{CCB} = 1.5V \pm 0.1V$		$V_{CCB} = 1.8V \pm 0.15V$		$V_{CCB} = 2.5V \pm 0.2V$		$V_{CCB} = 3.3V \pm 0.3V$		Units
			Typ	Min.	Max.	Min.	Max.	Min.	Max.	Min.	Max.	
t_{PD}	A	B	8	1.0	6.0	0.5	5.5	0.5	5.0	0.5	4.5	ns
	B	A	6	1.0	6.0	0.5	5.5	0.5	5.0	0.5	4.5	
$t_{SK(a)}^{(1)}$					0.25		0.25		0.25		0.25	
$t_{SK(b)}^{(1)}$					0.2		0.2		0.2		0.2	
f_{MAX} 10pF load	B	A	25	35		45		55		65		MHz
	A	B	30	40		45		50		55		

Timing Characteristics for $V_{CCA} = 2.5V \pm 0.2V$

(Over recommended free-air temperature range, unless otherwise noted.)

Parameter	From (Input)	To (Output)	$V_{CCB} = 1.2V$	$V_{CCB} = 1.5V \pm 0.1V$		$V_{CCB} = 1.8V \pm 0.15V$		$V_{CCB} = 2.5V \pm 0.2V$		$V_{CCB} = 3.3V \pm 0.3V$		Units
			Typ	Min.	Max.	Min.	Max.	Min.	Max.	Min.	Max.	
t_{PD}	A	B	8	1.0	5.5	0.5	5.0	0.5	4.5	0.5	4.0	ns
	B	A	6	1.0	5.5	0.5	5.0	0.5	4.5	0.5	4.0	
$t_{SK(a)}^{(1)}$					0.25		0.25		0.25		0.25	
$t_{SK(b)}^{(1)}$					0.2		0.2		0.2		0.2	
f_{max} 10pF load	B	A	30	40		50		75		80		MHz
	A	B	40	50		55		75		80		

Note:

1. This is the skew between any two outputs of the same package, and switching in the same direction. For $t_{SK(a)}$, Output 1 and Output 2 are any two outputs. For $t_{SK(b)}$, Output 1 and Output 2 are in the same bank. These parameters are warranted but not production tested.

Timing Characteristics for $V_{CCA} = 3.3V \pm 0.3V$

(Over recommended free-air temperature range, unless otherwise noted.)

Parameter	From (Input)	To (Output)	$V_{CCB} = 1.2V$	$V_{CCB} = 1.5V \pm 0.1V$		$V_{CCB} = 1.8V \pm 0.15V$		$V_{CCB} = 2.5V \pm 0.2V$		$V_{CCB} = 3.3V \pm 0.3V$		Units
			Typ	Min.	Max.	Min.	Max.	Min.	Max.	Min.	Max.	
t_{pD}	A	B	7	1.0	5.0	0.5	4.5	0.5	4.0	0.5	3.5	ns
	B	A	6	1.0	5.0	0.05	4.5	0.5	4.0	0.5	3.5	
$t_{SK(a)}^{(1)}$					0.25		0.25		0.25		0.25	
$t_{SK(b)}^{(1)}$					0.2		0.2		0.2		0.2	
f_{max} 10pF load	B	A	30	40		55		80		90		MHz
	A	B	40	60		65		80		90		

Note:

- This is the skew between any two outputs of the same package, and switching in the same direction. For $t_{SK(a)}$, Output 1 and Output 2 are any two outputs. For $t_{SK(b)}$, Output 1 and Output 2 are in the same bank. These parameters are warranted but not production tested.

Operating Characteristics (V_{CCA} and $V_{CCB} = 2.5V$, $T_A = 25^\circ C$)

Parameter		Test Conditions	Typ.	Units
$C_{pd}^{(1)}$ (V_{CCA})	Power Dissipation Capacitance A to B	Outputs Enabled	15	pF
		Outputs Disabled	2	
	Power Dissipation Capacitance B to A	Outputs Enabled	30	
		Outputs Disabled	10	
$C_{pd}^{(1)}$ (V_{CCB})	Power Dissipation Capacitance A to B	Outputs Enabled	30	pF
		Outputs Disabled	10	
	Power Dissipation Capacitance B to A	Outputs Enabled	15	
		Outputs Disabled	2	

Notes:

- This parameter is specified under test mode conditions.

Parameter Measurement Information

V_{CCA}/V_{CCB}	C_L
1.2V ~ 1.6V	10pF
1.8V ±0.15V	20pF
2.5V ±0.2V	30pF
3.3V ±0.3V	50pF

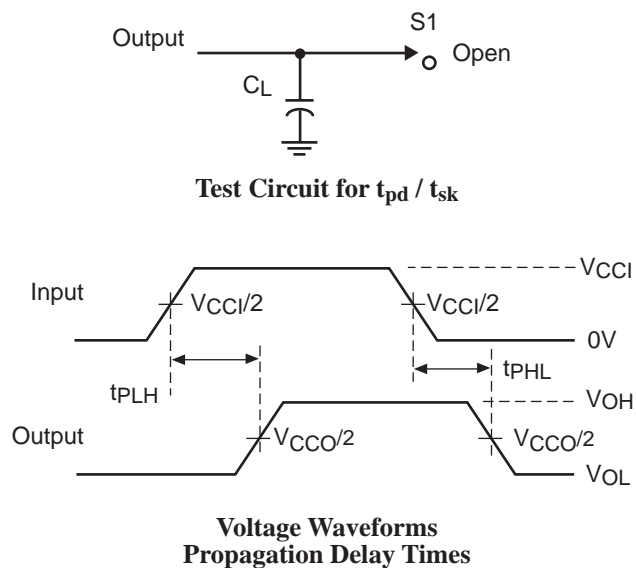
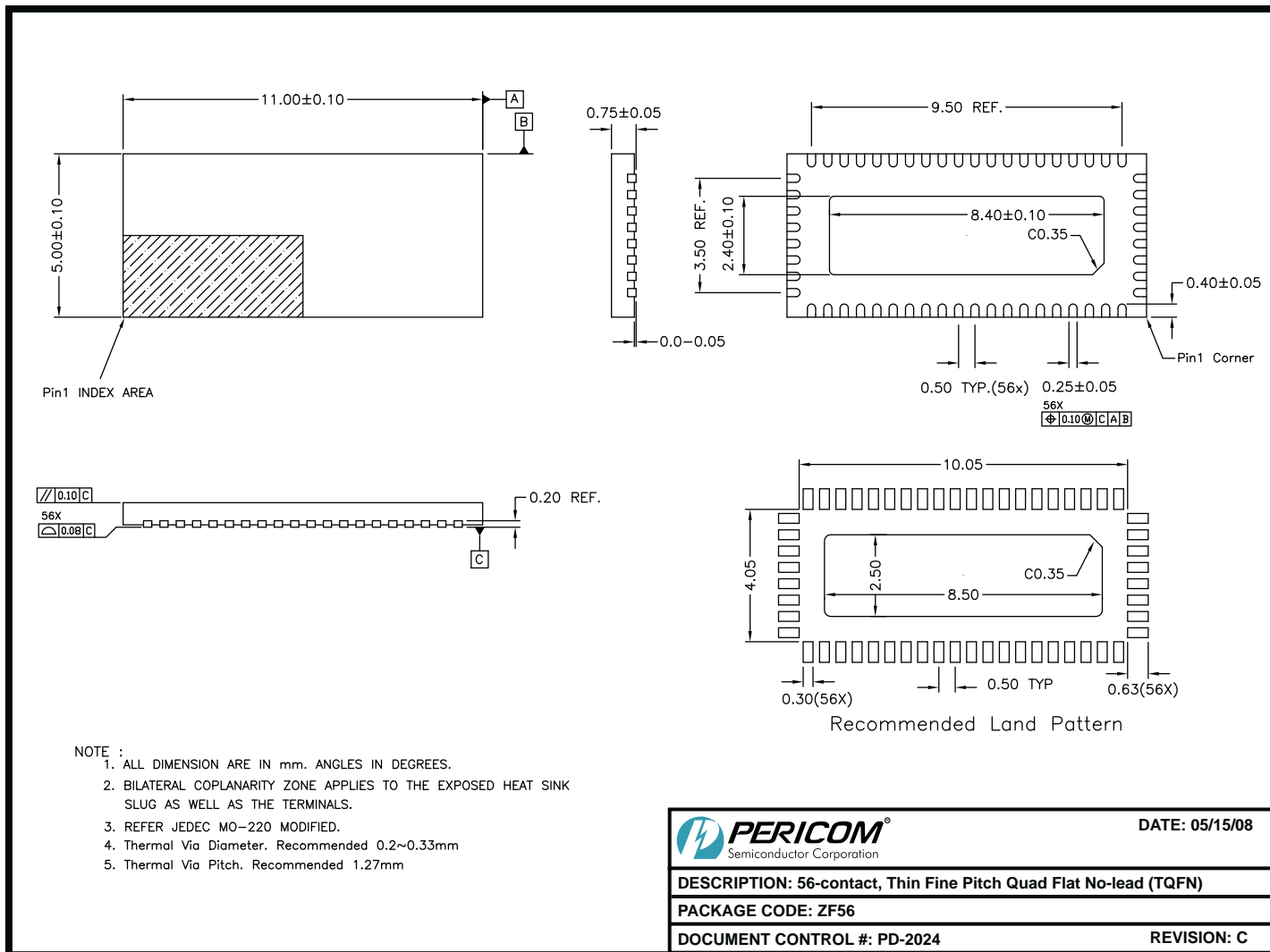

Figure 1. Load Circuit and Voltage Waveforms

Notes:

- C_L includes probe and jig capacitance.
- Waveform 1 is for an output with internal conditions such that the output is low except when disabled by the output control.
Waveform 2 is for an output with internal conditions such that the output is high except when disabled by the output control.
- All input pulses are supplied by generators having the following characteristics: $PRR \leq 10\text{Mz}$, $Z_O = 50\Omega$, $t_r \leq 2.5\text{ns}$, $t_f \leq 2.5\text{ns}$.
- The outputs are measured one at a time with one transition per measurement.
- t_{PLZ} and t_{PHZ} are the same as t_{DIS} .
- t_{PZL} and t_{PZH} are the same as t_{EN} .
- t_{PLH} and t_{PHL} are the same as t_{PD} .
- V_{CCI} defines the input port (V_{CCA} or V_{CCB}).
- V_{CCO} defines the output port (V_{CCA} or V_{CCB}).



Ordering Information

Ordering Code	Packaging Code	Package Description
PI4ULS3V16ZFE	ZF	Pb-free & Green, 56-contact, 197-mil wide plastic TQFN

Notes:

- Thermal characteristics can be found on the company web site at www.pericom.com/packaging/
- E = Lead-free and Green
- Adding X suffix = Tape/Reel